

Aspiration Box

The Aspiration Box, 1502 Series, is used for easy duct mounting of Engelhard's 2000 series CO₂ sensor. Sampling CO₂ inside the duct allows the user to monitor CO₂ levels over a larger area. This unit can also be converted into wallmount to monitor a specific area.

INSTALLATION

The Aspiration Box, Model 1502, may be installed on the top or side of the return air duct.

1. Before mounting the Aspiration Box, note the direction of the air duct flow. The airflow should be flowing in the direction of the **three holes**.

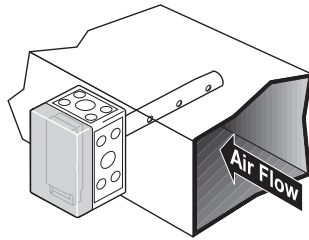

2. Using the template provided, mark the four mounting holes and one 1-1/4" hole (for inlet tubing) on the duct.

3. Punch out the four mounting holes and one 1 1/4" air inlet hole.

4. Next, prepare the kit for mounting by removing the four screws on the plexiglas cover.

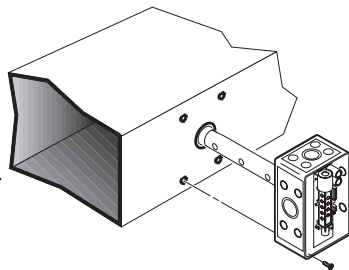

5. Mount the Aspiration Box to the duct using four sheet metal screws, verifying the three cutouts on the inlet tube are facing the airflow.

6. Pass electrical wiring through the desired conduit hole and make all necessary wiring connections to the terminal blocks. *Refer to table on the reverse side of this sheet for electrical rating and terminal block designations.* Ensure an airtight seal by caulking the opened conduit holes.

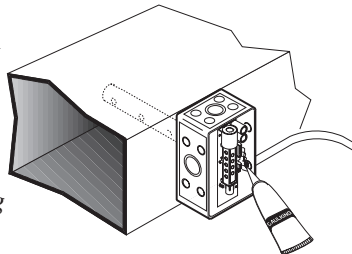

7. Because return air is at a static zero or negative pressure, relative to ambient air, it is vital that the box be completely sealed. This includes areas where the control wiring enters the box and where the perforated tubing enters the box. Once the Aspiration Box is mounted, the return air will enter the inlet holes of the perforated tube, circulate through the sensor chamber and exhaust through the exit slots on the other side of the tube.

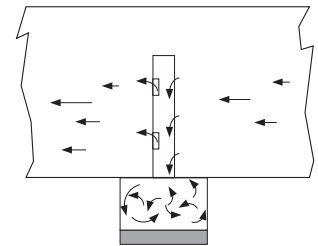

8. Close the Aspiration Box cover and screw tightly to prevent ambient air from entering the sensor chamber. The 2001V cover is not needed for duct mounted applications, you may wish to keep it in the event that the sensor's sampling location is changed (e.g. wall mounted).

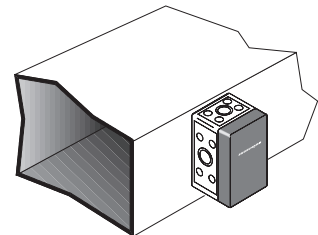

ENGELHARD

Terminal Block

The table below lists the terminal block designations and maximum electrical ratings for the unit.

Terminal Number	Terminal Designation	Maximum Electrical Ratings		
		Voltage	Sink Current	Source Current
TB-1	Power Supply	20-30 VAC (RMS) contact factory for DC	500 mA	
TB-2	Not Used			
TB-3	Relay Contact	24 V	1.5 A AC; 750 mA DC	
TB-4	Relay Contact	24V	1.5 A AC; 750 mA DC	
TB-5	Power Ground			
TB-6	RS-232 (Tx)	EIA Standard		
TB-7	RS-232 (Rx)	EIA Standard		
TB-8	RS-232 (Ground)	EIA Standard		
TB-9	+ V Out or	10 VDC	10 mA	
	Current Source		20 mA	
TB-10	Signal Ground or	0 VDC	10 mA	
	Current Sink			20 mA

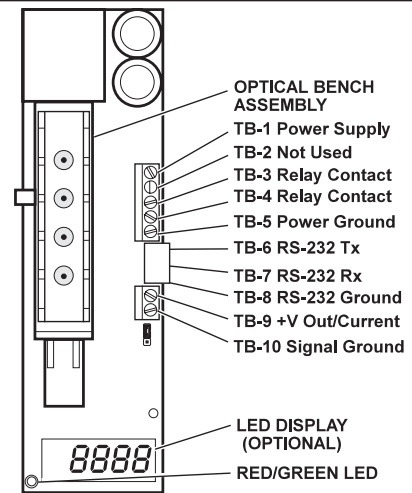

Note All wiring connections must be made in accordance with the National Electrical Code and all local regulations for low voltage wiring.

Dimensions

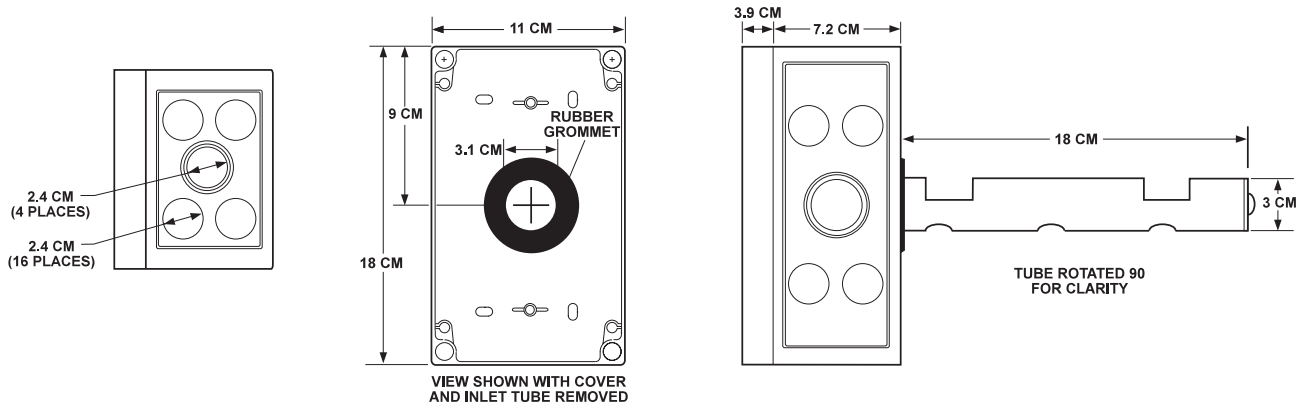

Specifications

Accuracy:

At Constant Temp (78°F)
20 ppm (also repeatability)

Typical Conditions
(60°- 90°F) ±2.5% of reading or ±50 ppm whichever is greater

Extended Conditions (2001V)
(32°-145°F) ±5% of reading or ±100 ppm whichever is greater

% Change In Reading Per °F
±0.05% of reading

Pressure Dependence
0.19% per mm hg

Annual Drift
<20 ppm with TEMA Self Calibration Feature

General Performance

EMI Interference
FCC Part 15 Class B

Certification

Certified By The California Energy Commission

Shock Resistance

40 Gs

Sensor Life

15 years

Operating Humidity Range

0-95% RH (non Condensing)

Dimensions

Sensor: 6.4" X 2.2" X 1.7" (16 oz)

Power Input

20-30 VAC (RMS) 60 Hz/Contact factory for DC

Isolation Transformer

Not required (half wave rectification on board)

Output

Optional Display

4 Digit Green LED Display

Analog Output Maximum Range

0-10 V or 4-20 mA (jumper selected on circuit board)

Analog Output Customizing

Can be set to any output within maximum range using PC based User Interface Program (UIP)

Measurement Range

Fully adjustable using PC based program & RS-232 interface. Max: 0-10,000 ppm

Relay

Gold bifurcated, 2 A rating, close on CO2 rise

Relay Contact Resistance

100 mW max (measured at 6V DC, 0.1 A)

User Relay Adjustments

Setpoint and dead-band via PC based UIP

The Ventostat® 2001V is Protected by United States Patents: 5,060,508 and 5,163,332

ENGELHARD

6489 Calle Real Goleta, CA 93117 805.964.1699 FAX 805.964.2129

Engelhard seeks to present reliable information concerning the composition, properties and use of its products, however; (1) All advice concerning selection and use of any product is provided at no charge and with no warranty. (2) No warranty is made hereby. Products described herein are warranted to conform to Engelhard's specifications only at the time of sale. All sales are subject to Engelhard's standard terms and conditions, which are reproduced on the reverse side of each invoice. All warranties of merchantability and fitness of purpose are disclaimed and remedy for any breach of warranty is limited to replacement of the defective product. (3) Engelhard assumes no responsibility for any patent liability arising from the use of any product in a process, manner of formula not designed by Engelhard.

©Copyright 1996, Engelhard Corporation

This Engelhard product has been examined and tested for proper operation. Please operate this product only in accordance with the instructions.

Engelhard Sensors warrants this product against defects in workmanship and materials for a period of 18 months from the date of purchase by the original owner. If the product should become defective within this warranty period we will repair or exchange it. A return authorization number must be obtained from the factory prior to returning equipment. Items received without a return authorization number will be refused. Product to be serviced under this warranty should be sent to Engelhard, 6489 Calle Real, Goleta, CA 93117. Shipment must be prepaid, properly packed and insured. Engelhard is not and will not be liable for any consequential loss or damages that may occur by reason of purchase and use of this product. The responsibility of Engelhard, in any event, is strictly limited to the replacement/repair of the product.