

# SPECIALTY SENSORS

## VIBRATION TRANSMITTER MODEL 140T



### DESCRIPTION

A low cost, highly accurate and rugged vibration transmitter, the **Model 140T** is ideal for use with all machines, even those that previously may have been considered uneconomical to monitor.

The **Model 140T** easily mounts by use of a standard 1/4-20 stud. It is a two-wire, loop-powered transmitter that can feed the vibration level of operating machinery to a data logger, milliamp monitor, or process control computer. Solid-state accelerometer and circuit design provide a 4-20 mA signal proportional to vibration velocity. Intrinsically safe, it can safely be used in hazardous environments when coupled with a Model MTL7206 intrinsic safety barrier.



### FEATURES

- **Reliable performance**
- **Easy to install**
- **4-20 mA signal compatible with most BAS controllers**
- **Intrinsically safe Class I, Division 1, Groups A,B,C; Class II, Division 1, Groups E, F, G**
- **Two-year warranty**

### APPLICATION

Vibration monitoring can provide help in alerting for the destructive effects of vibration on mechanical system equipment, such as the following:

- **Air handler fans**
- **Cooling tower fans**
- **Pumps**
- **Compressors**

### DIMENSIONS

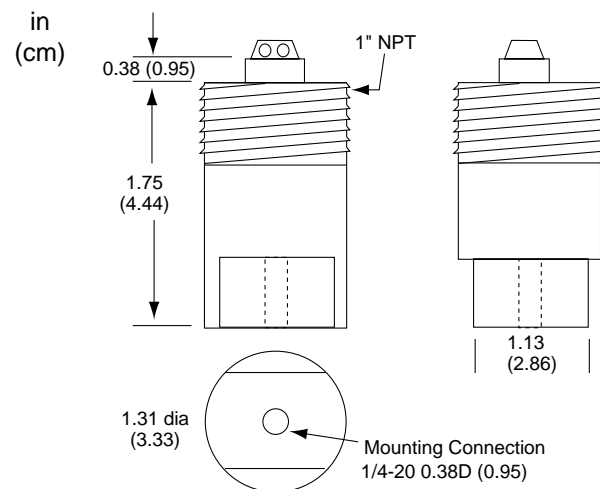

### SPECIFICATIONS

<b>Vibration range</b>	Output 4-20 mA, proportional to vibration level	<b>Conduit connection</b>	1" MNPT
<b>Model 140T-1</b>	0-1 in/sec	<b>Max load resistance</b>	RL = 50 (Vs-12) ohms 600Ω @ 24 VDC
<b>Model 140T-2</b>	0-2 in/sec	<b>Temp range</b>	-4° to 185°F (-20° to 85°C)
<b>Frequency range</b>	7-1300 Hz ±3% (420-78,000 rpm)	<b>Environment rating</b>	NEMA 4, weatherproof
<b>Accuracy</b>	5% to 10% of scale	<b>Case</b>	Cadmium-plated steel
<b>Supply voltage (Vs)</b>	12-50 VDC, unregulated; black=negative, red=positive, with reverse voltage protection	<b>Mounting</b>	1/4"-20 stud
<b>Isolation</b>	500V, circuit-to-case	<b>Weight</b>	1.4 lb (0.64 kg)

# SPECIALTY SENSORS



## VIBRATION TRANSMITTER

### MODEL 140T

#### INSTALLATION

The mounting orientation can be in any position. This position should be in an area for the best vibration signal definition or where there is a good transfer of the machine's (fan's, pump's, etc.) vibrations. The best location will vary from machine to machine. The location of the transmitter should be selected carefully. When selecting the site for the mounting location, it is helpful to survey the site with the aid of a vibration meter.

#### WIRING

Wiring subject to physical damage should be adequately protected. When installing electrical conduit, it is recommended that a short length (12") of flexible conduit be used between the transmitter and an associated junction box. This construction will provide some vibration isolation in the conduit line. Conduit and fittings should conform to the environment of the transmitter location. Weather-resistant or rain-tight fittings should be used to protect the transmitter wiring from a humid or corrosive atmosphere.

Note: Make all connections in accordance with national and local codes.

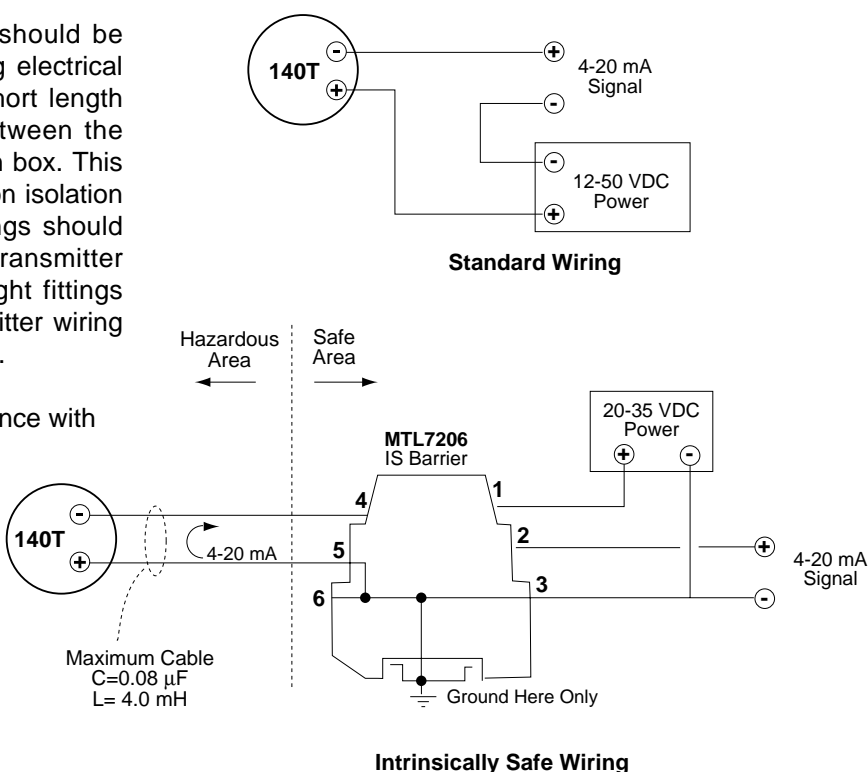

**CAUTION:** Ensure that the transmitter is rigidly attached to the monitoring point for the proper sensing of the vibration.

#### ORDERING INFORMATION

<u>MODEL</u>	<u>RANGE</u>
140T-1	0-1 in/sec
140T-2	0-2 in/sec

Note: Each application should be evaluated on an individual basis. Consult equipment manufacturers for specific details concerning safe vibration levels.